

# EverPump™

## Dual Pump control/monitor



## User Guide

Revision 1.0

Orbit Communications Pty Ltd  
Unit 1, 16 Donaldson Street  
Wyong, NSW 2259  
Australia

Phone +61 (2) 43 554 554

Fax +62 (2) 43 554 994

Email [sales@orbitcoms.com](mailto:sales@orbitcoms.com)

Web [www.orbitcoms.com](http://www.orbitcoms.com)

All right reserved  
Copyright Orbit Communications Pty Ltd, 2010

## Table of Contents

Introduction	4
Operation	5
LED Status Panel	6
Master Wiring Diagram	7
Remote Wiring Diagram	8
Digital Inputs	9
Digital Outputs	9
Relay Connections	10
Safety Precautions	11
Warranty	12

# Introduction

The Dual-Channel wireless pump control system is designed to control two remote pumps from a central point. The system also returns the state of two inputs at each of the remote pumps back to the central point.

The wireless unit located at the central point is referred to as the “Master Unit” and the wireless devices located at the remote pump locations are referred to as “Remote Units”.

The Master Unit typically is connected to some form of irrigation or other control system (example: BMS or PLC). Pump control output signals from the BMS/PLC will then switch the remote pumps ON or OFF as required. The two status signals from the Remote Units are available as outputs at the Master Unit that the BMS/PLC system can read as required.

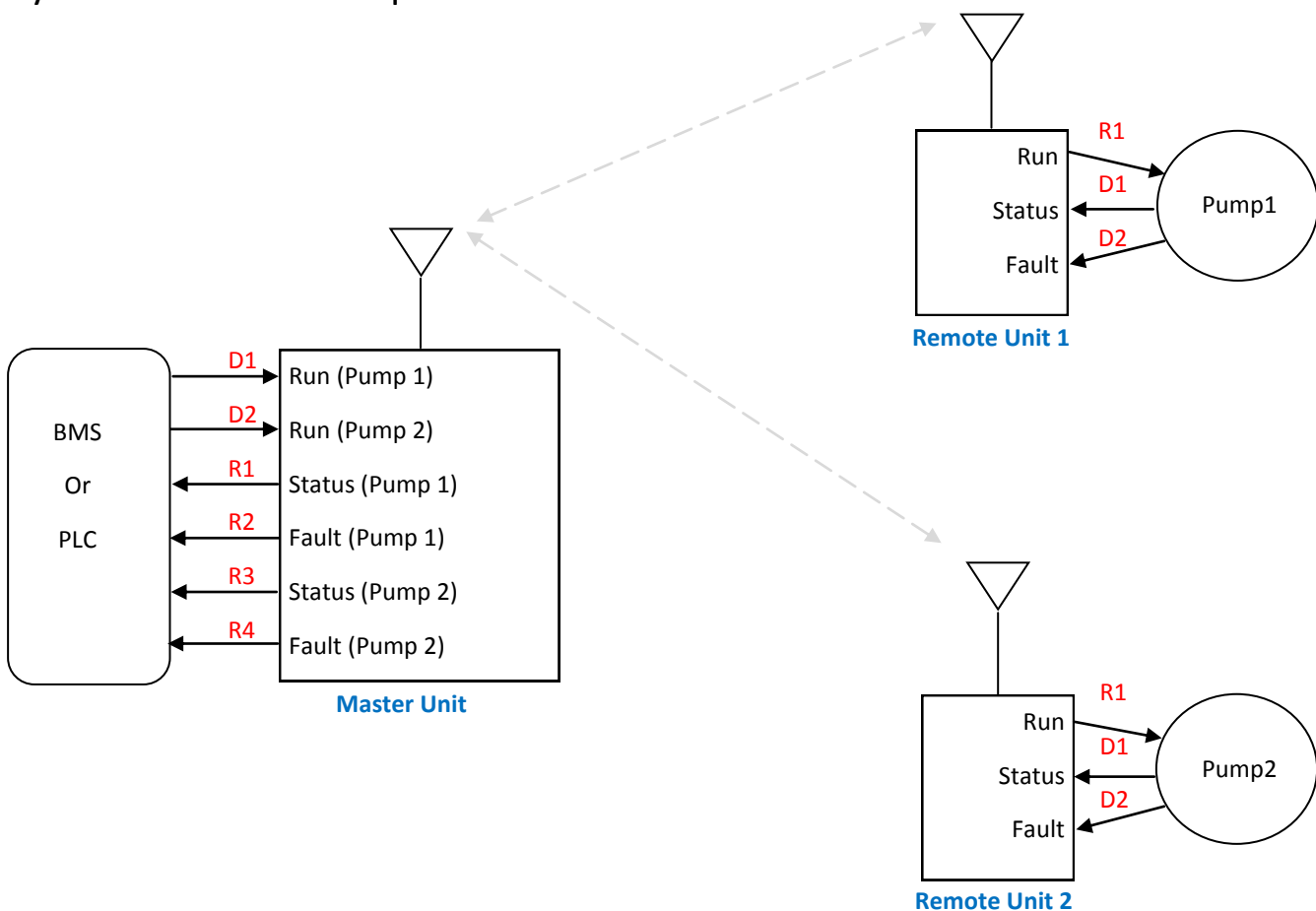

**Figure 1. System Overview Diagram**

## Operation

### 1. Master Unit Reads Pump RUN states from BMS/PLC for BOTH Pumps

The BMS/PLC Pump RUN signal outputs for Pump 1 and Pump 2 are connected to “D1” and “D2” inputs of the Master Control Unit respectively.

The Master Unit reads the RUN signal outputs from the BMS/PLC controller system approximately every 5 seconds.

### 2. Master Unit sends RUN State to Remote Unit 1

The Master Unit first sends the Pump RUN signal state to Remote Unit 1.

### 3. Remote Unit 1 Responds

Remote Unit 1 will switch the pump control relay (connected to “R1”) ON or OFF in accordance with the state of the Pump control input at the Master Unit.

A LOW signal at the Master Unit will cause the Pump control relay to switch ON and a HIGH/FLOATING signal will cause the Pump control relay to be switched OFF.

The Remote Unit will then read the STATUS input (“D1”) and the FAULT input (“D2”)

And immediately send the state of the PUMP, STATUS INPUT and FAULT INPUT back to the Master Unit.

### 4. Master Unit processes response from Remote Unit 1

The Master Unit will set the STATUS output for Pump 1 (“R1”) and the FAULT output for Pump 1 (“R2”) accordingly. (A HIGH/FLOATING input at remote input will result in corresponding HIGH/FLOATING state at the Master Unit outputs).

### 5. Sequence steps (2) to (4) Repeat for Remote Unit 2

### 6. System applies 5 second delay

## LED Status Panel

The LED status panel plugs into a 10-way black connector on the left hand side of the Master Unit and Remote Unit controller PCB. This board provides indication of the link activity and states of Pumps.

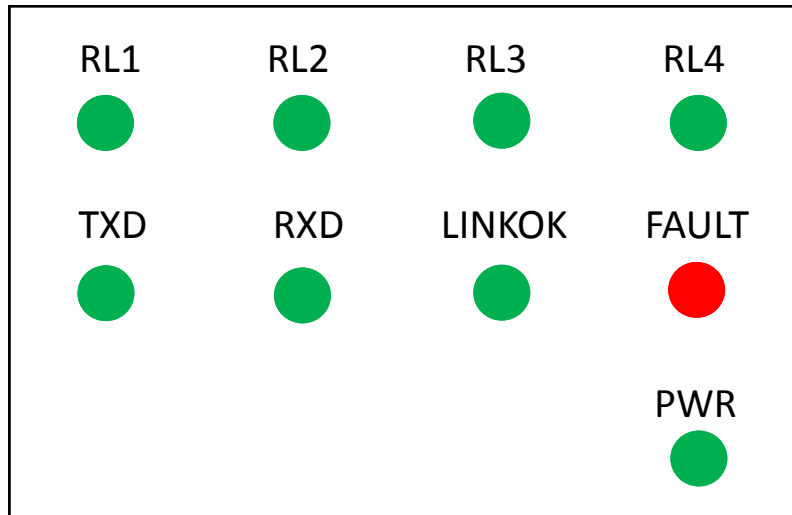

Figure 2. LED Status Panel

LED	Description	Function
RL1	Pump 1 Run State	ON = Pump 1 on, OFF = Pump 1 off
RL2	Pump 2 Run State	ON = Pump 2 on, OFF = Pump 2 off
RL3	Remote 1 OK	ON = Remote Unit 1 OK, OFF = No response
RL4	Remote 2 OK	ON = Remote Unit 2 OK, OFF = No response
TXD	Transmit Activity	Blinks sending data (5 second interval) to
RXD	Receive Activity	Blinks when receiving data from Remote Unit
LINKOK	Healthy Radio Link	ON when Radio link OK, OFF if Radio link fault
FAULT	Faulty Radio Link	ON when any Radio Fault, OFF when link OK
PWR	Power OK	ON when power applied to unit

Table 1. Functions of LED Status Panel

*Note: RL2, RL3 and RL4 not used on Remote LED Status Panels.*

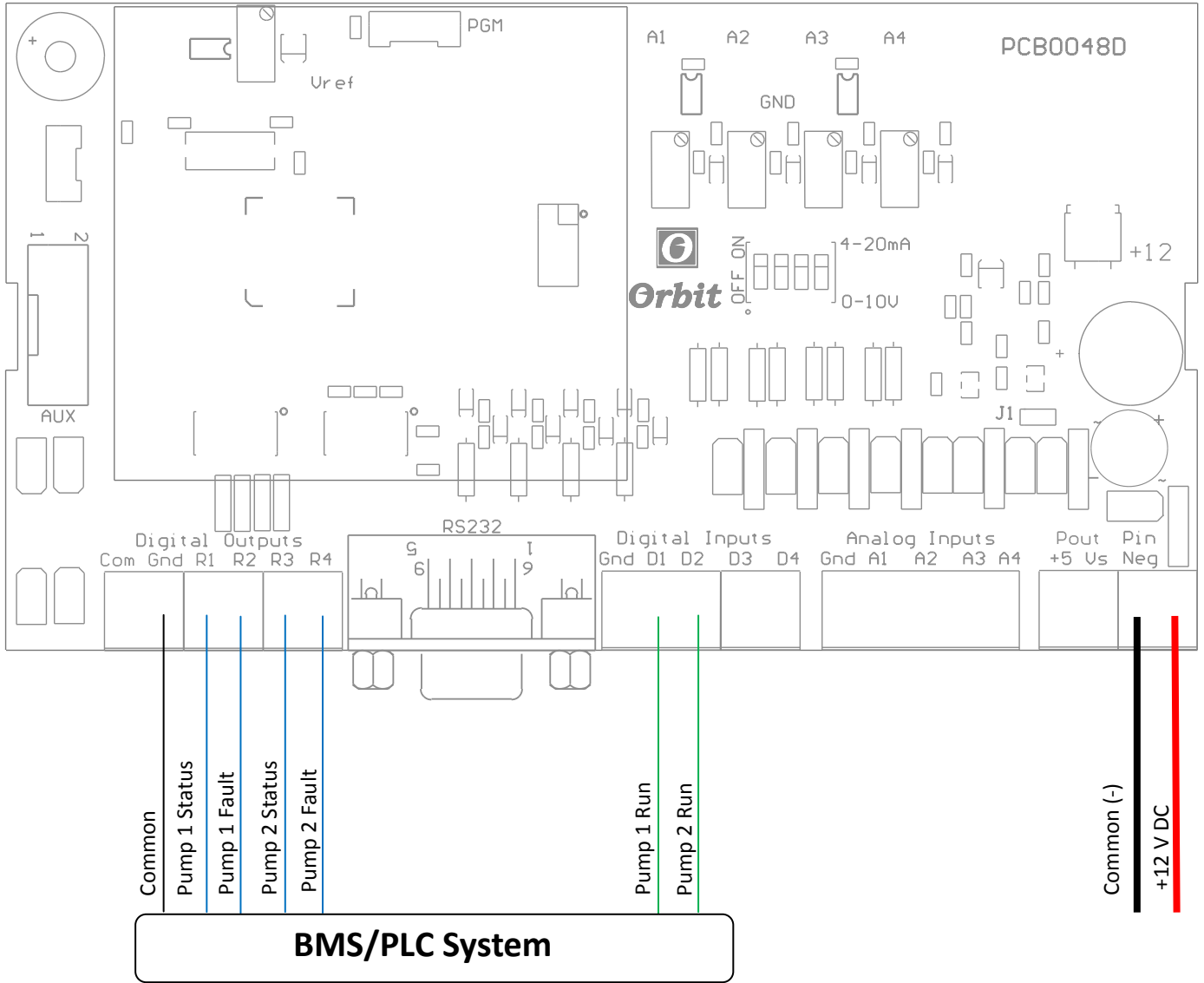
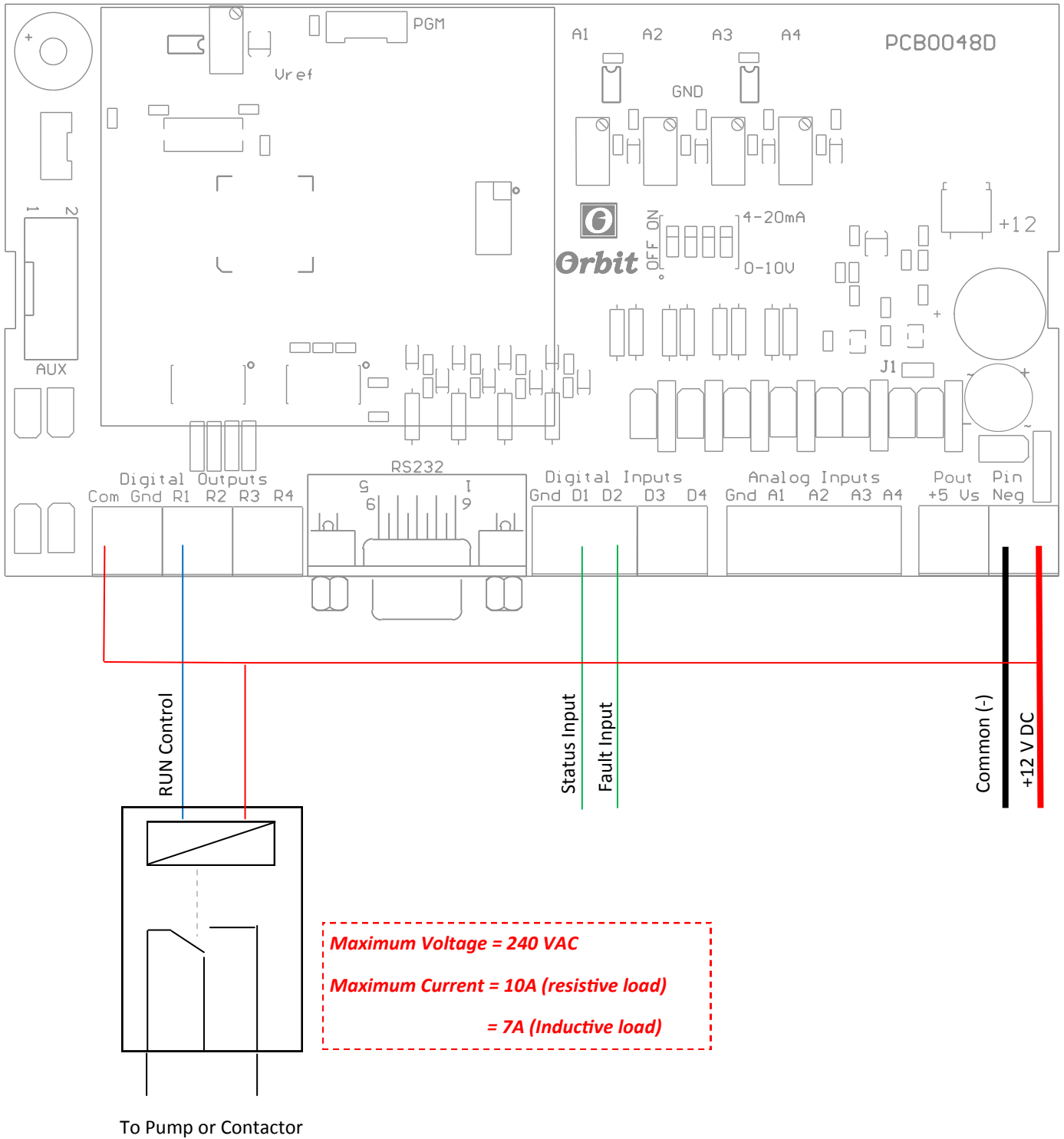

Figure 3. Wiring diagram for Master Unit



**Figure 4. Wiring diagram for Remote Pump Unit**

## Digital Inputs

The Digital Inputs are pulled up to +5V DC via an internal pull-up resistor. The inputs can tolerate over voltage and reverse polarity voltage to +/- 30V DC. ***Voltages applied outside of this range may cause damage.***

The Digital inputs can be operated using any voltage free contact (such as a Relay contact, open drain or open collector output from another device or a switch), the input can also be connected to a voltage source (recommend 0V to 10V maximum). Note: The Common side of the input devices must connect to the GROUND terminal of the RTU device.

## Digital Outputs

The RTU Digital outputs are Open Collector type and can tolerate a maximum applied voltage of 50VDC and a sink maximum current of 500mA.

Typical applications use the Digital outputs to control relay coils. The outputs are also suitable to connect directly to inputs of other devices (such as a PLC) that require Voltage-Free inputs or for driving indicators such as LEDs.

# Relay Connections

The supplied relay provides two changeover relay contacts. The recommended method is to connect the Pump or contactor between Normally OPEN (N/O) and Common contacts (either A or B as shown below). The relay contacts are rated up to 240VAC and current handling capacity to 7 Amps for an inductive load (such as a motor) and 10 Amps for resistive loads.

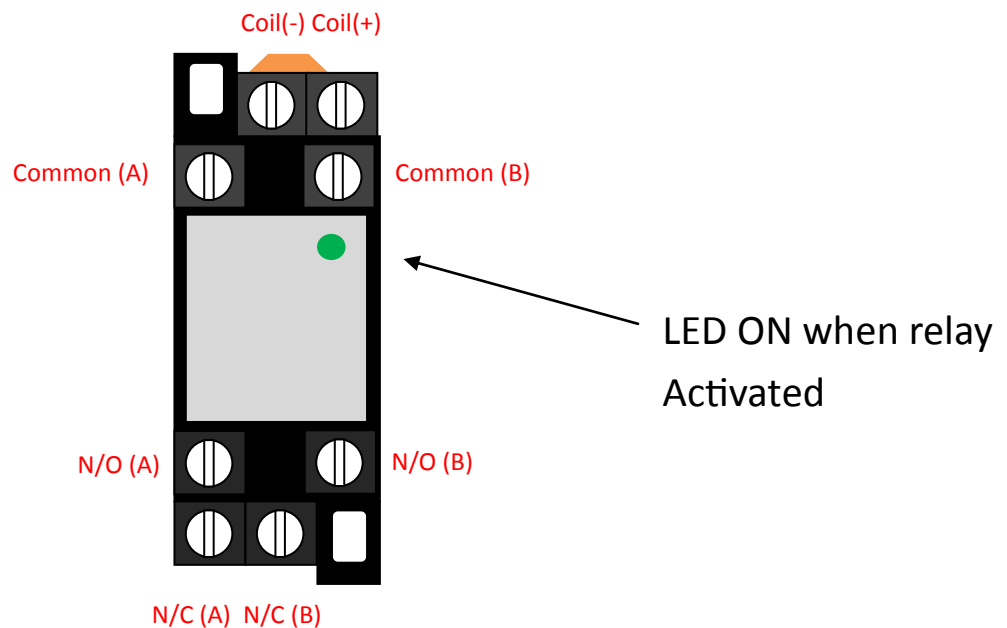

Figure 4. Relay Contact Details

## Fitting PCB to DIN Rail

Tilt rear of unit down to enable base to clip onto back of DIN rail

Lower front and press onto DIN rail until locking mechanism clicks into place

## Removing PCB from DIN Rail

Use small screwdriver for pull locking TAB (at front of unit) toward you.

Lift Unit up at front and then and away from DIN Rail

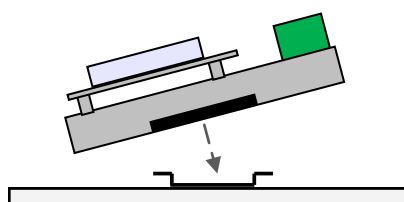

Figure 5. PCB attachment to DIN rail

## Safety Precautions

The following safety precautions must be observed whenever the Orbit wireless device system is in operation or in service. Failure to comply with these precautions violates the safety standards of the design, manufacture and intended use of the product

- The system is not to be used:

In hospitals or places where medical equipment may be in use.

In an aircraft (whether on the ground or in the air)

Refuelling points

Explosive areas

- Restricted use of the Orbit wireless device

Near any chemical plant

Near any Fuel depot

The Orbit wireless device system receives and transmits radio frequency energy while switched on, therefore interference can occur if the Orbit wireless device is located near TVs, radios, PCs or any inadequately shielded equipment.

### **WEEE directive 2002/96/EC, disposal of old electronic equipment**

This product shall not be treated as household waste. It must be placed at an appropriate collection point for the recycling of electrical and electronic equipment. By ensuring the correct disposal of this equipment, it will help the environment and human's health. The recycling will help to conserve the natural resources.

### **Important**

Due to the nature of wireless systems, transmission and reception of data can never be guaranteed. Data may be corrupted (i.e. Have errors) or be totally lost at certain times due to the environment, other machinery or malfunction of electronic components. Although significant loss of data are rare when wireless devices such as the Orbit wireless device system are used in a normal manner, Orbit's wireless device system should not be used in situations where failure to transmit or receive data could result in damage of any kind to the user or any other party, including but not limited to personal injury, death or loss of property. Orbit Communications Pty Ltd accepts no responsibility for damages of any kind resulting from errors in data transmitted or received using Orbit's Orbit wireless device systems, or for the failure of the Orbit wireless device system to transmit or receive such data.

Do not operate the Orbit wireless device system in areas where blasting is in progress, where explosive atmospheres may be present, near medical equipment, near life support equipment, or any equipment which may be susceptible to any form of radio interference, in such areas, Orbit's wireless device system must be powered OFF.

Do not operate Orbit wireless device system in any aircraft, whether the aircraft is on the ground or in flight. In an aircraft the Orbit wireless device system must be powered OFF.

The information in Orbit Communications Pty Ltd documents are subject to change without notice and do not represent a commitment on the part of Orbit Communications Pty Ltd. Orbit Communications Pty Ltd and its affiliates specifically disclaim liability for any and all direct, indirect, special, general, incidental, consequential, punitive or exemplary damages including, but not limited to, loss of profits or revenue or anticipated profits or revenue arising out of the use or inability to use any Orbit Communications Pty Ltd product, even if Orbit Communications Pty Ltd and/or its affiliates have been advised of the possibility of such damages or they are foreseeable or for claims by any third party.

Notwithstanding the foregoing, in no event shall Orbit Communications Pty Ltd and/or its affiliates aggregate liability arising under or in connection with the Orbit Communications Pty Ltd product, regardless of the number of events, occurrences or claims giving rise to liability, be in excess of the price paid by the purchaser for the Orbit Communications Pty Ltd product.

## Warranty

All products manufactured by Orbit Communications Pty Ltd are warranted to be free from defects in materials and workmanship under normal use and service for 36 months from the date of shipment unless otherwise specified. Orbit Communications' obligation under this warranty is limited to repairing or replacing (at Orbit's discretion) defective products. The customer shall assume all costs of removing, reinstalling and shipping defective products to Orbit Communications. Orbit Communications will return such products by surface carrier prepaid. This warranty shall not apply to any Orbit product that has been subject to modification, misuse, neglect, accidents of nature or shipping damage. This warranty is in lieu of all other warranties, expressed or implied, including warranties of merchantability or fitness for a particular purpose. Orbit Communications is not liable for special, indirect, accidental, or consequential damages.

Products may not be returned to Orbit Communications without prior authorization. To obtain a Returned Product Authorization (RPA), contact Orbit Communications by phone, fax or email. An RPA number will be issued after our staff determines the nature of the problem. Please write the RPA number on the outside of the shipping container. Any non-warranty products returned for repair should be accompanied by a purchase order to cover the cost of the repairs.