

EverPump™

Wireless Pump control system



User Guide

Revision 1.0

Orbit Communications Pty Ltd
Unit 1, 16 Donaldson Street
Wyong, NSW 2259
Australia

Phone +61 (2) 43 554 554

Fax +62 (2) 43 554 994

Email sales@orbitcoms.com

Web www.orbitcoms.com

All right reserved
Copyright Orbit Communications Pty Ltd, 2010

Table of Contents

Introduction	4
How it works	5
LED Status Panel	6
Tank Status Panel	7
Pump Status Panel	8
Tank Wiring	11
Pump Wiring	12
Digital Inputs	13
Digital Outputs	13
Relay Connections	14
Safety Precautions	15
Warranty	16

Introduction

The EverPump wireless pump control system is designed to maintain the tank level between an Upper (HIGH) and Lower (LOW) level limit. The HIGH and LOW levels of the tank are determined by fitting float-switches at the desired levels. Both float switches should be configured to **CLOSE** contacts when they are active (i.e. The LOW float switch should be normally-open and **close** when tank level falls below the float switch position, the HIGH float switch should also be normally-open and **close** when the level in the tank exceeds the HIGH level).

During normal operation the Tank unit will monitor the level of the tank and instruct the Pump Unit to switch the Pump ON or OFF as required to maintain the correct level. In the event of a fault (such as invalid float switch state or loss of radio communications), the Pump Unit will indicate an alarm condition and switch the pump OFF. Additional float switches can be added for Overflow detection (if placed physically above the HIGH float) or Tank Empty detection (if placed below the LOW float level). An optional Pressure or Flow switch can be fitted to the water feed line and connected to the Pump unit input. This prevents the pump from running dry if the Pump control relay is instructed to switch ON and after a time period (10 minutes) the water flow or pressure is not established then the alarm will be set and the pump control relay will be switched OFF.

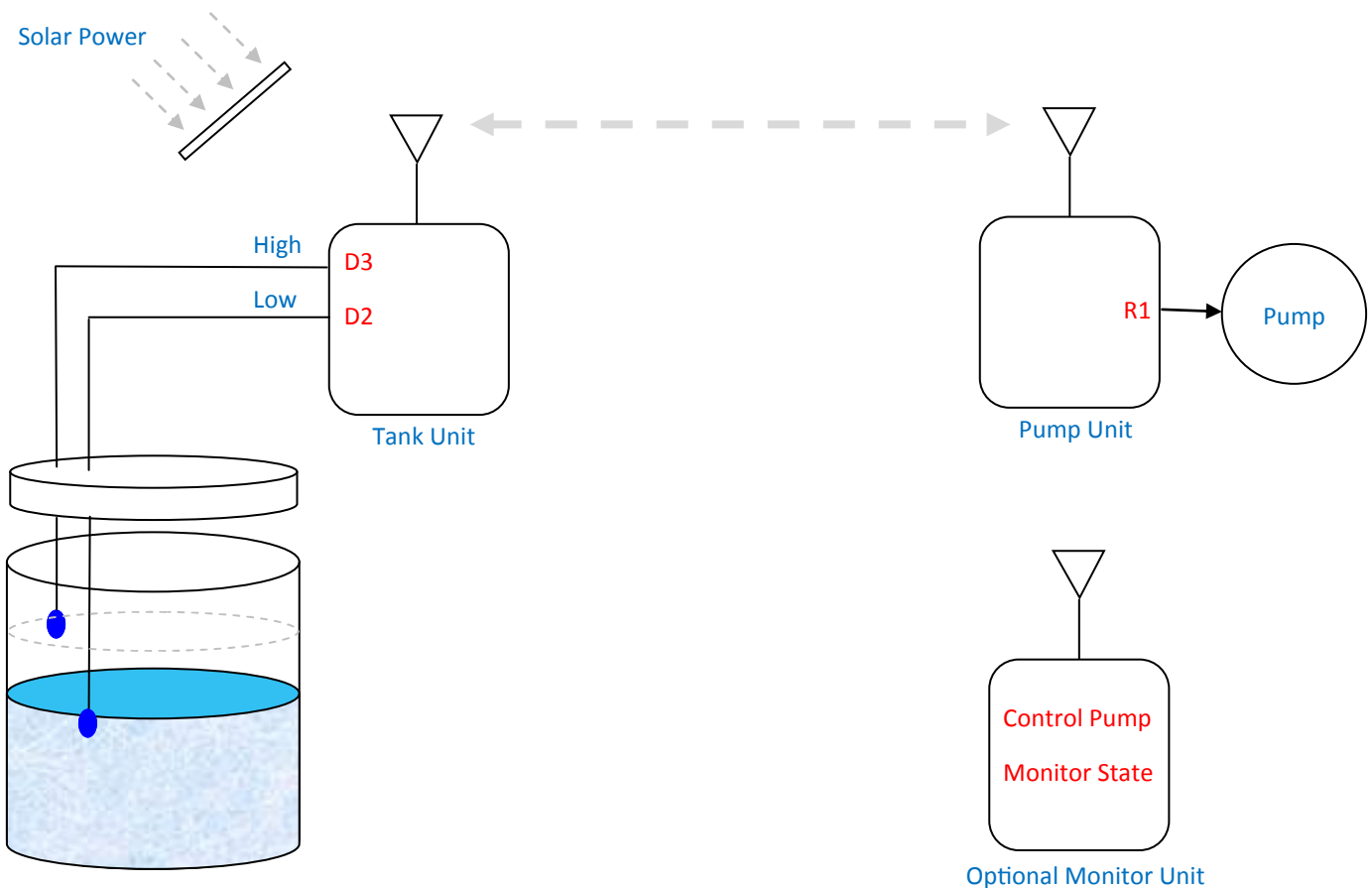

Figure 1. System Overview Diagram

How it Works

The Tank Unit continuously monitors the state of the tank and sends tank state level information to the Pump Unit.

The Tank unit will send the signal immediately when a float switch changes state.

During times when no changes occur in float switch states, the Tank unit and Pump unit will communicate at regular intervals (15 minutes) to ensure the radio link is working correctly.

If the Tank Unit does not receive a response from the Pump unit within any 40 minute period then a Fault condition will be indicated at both ends of the link and a SMS text alarm message will be sent to your mobile phone (if GSM option is fitted). Under a Fault condition, the Pump control relay will also be switched OFF until the Fault condition has been rectified.

Typical Normal Control Cycle

For the sake of this explanation we assume the existing tank level is somewhere between the HIGH and LOW levels and the pump is currently OFF.

The tank will begin to drain as water is being used. Once the tank level falls below the LOW level, the LOW float switch will be activated (contacts CLOSE) and the Tank Unit will inform the Pump Unit to switch the pump control relay ON.

The Pump switches ON.

Once the pump is running the tank level will begin to rise. As the tank level reaches it eventually activates the HIGH level float switch (contacts CLOSE) and the Tank Unit informs the Pump Unit to switch the Pump control relay OFF.

After the pump is switched OFF the tank level again begins to fall and the cycle is repeated.

This control cycle will continue indefinitely unless...

- The pump does not switch OFF (causing level of the tank continues to rise). If a float has been installed in a position above the HIGH level then the both the tank and pump unit will indicate a Fault condition and the pump control relay will switch off. If the optional GSM dialler is fitted, an SMS text alarm message will be sent to your mobile phone.
- A break in the water feed line or the pump runs dry (causing tank to continue to empty even when pump is running). If a float has been installed below the LOW level float or a pressure/flow switch has been connected to the Pump Unit input then the Fault condition will be indicated at each end of the link and the Pump control relay will switch OFF. If the optional GSM dialler is fitted then an SMS alarm message will be sent directly to your mobile phone.

- More than 1 float is active (Closed) at any time then a fault condition will be indicated at both Tank and Pump unit, the Pump control relay will be switched OFF and if the optional GSM dialler is fitted then a SMS alarm message will be sent to your mobile phone.
- The Radio link has an error then a fault condition will be indicated at both Tank and Pump unit, the Pump control relay will be switched OFF and if the optional GSM dialler is fitted then a SMS alarm message will be sent to your mobile phone.
- The Supply voltage at the Tank Falls below 10.6V DC. For Solar powered systems this could indicate a fault with the solar panel or battery. In event of a Low Battery a fault condition will be indicated at both Tank and Pump unit, the Pump control relay will be switched OFF and if the optional GSM dialler is fitted then a SMS alarm message will be sent to your mobile phone. The Restore level for Battery is 11.6V

GSM Note: Whenever a Fault condition is rectified, an SMS RESTORE message is sent to your phone (identifying what condition has been restored) to your mobile phone and the normal control cycle will proceed.

Indicators

Both the Tank Unit and Pump Unit have a LED Status panel that shows the current state of the system. Note: *It is recommended for Solar Powered Tank units that the LED display panel be disconnected once the system has been set up to reduce current draw from the battery.*

LED Status Panel—Tank Unit

The LED status panel plugs into a 10-way black connector on the left hand side of the Master Unit and Remote Unit controller PCB. This board provides indication of the link activity and states of Pumps.

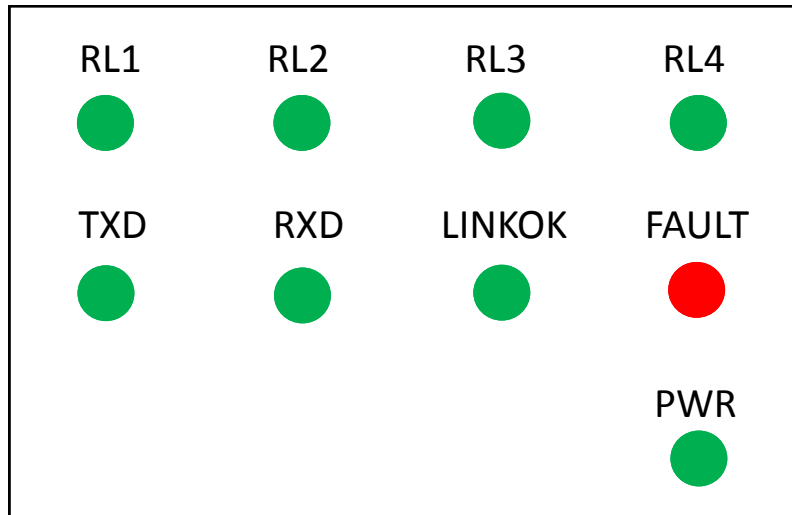

Figure 2. LED Status Panel

LED	Description	Function
RL1	Pump ON	ON = Pump 1 on, OFF = Pump 1 off
RL2	Floats OK	ON = Floats OK, OFF = Float Error
RL3	Battery OK	ON = Tank Battery > 11.6V, OFF = Battery Low
RL4	Level OK	ON = Water level between Float Switches
TXD	Transmit Activity	Blinks when sending data to Pump Unit
RXD	Receive Activity	Blinks when receiving data from Remote Unit
LINKOK	Healthy Radio Link	ON when Radio link OK, OFF if Radio link fault
FAULT	Fault Detected	ON when any Radio Fault, OFF when link OK
PWR	Power OK	ON when power applied to unit

Table 1. Functions of Tank LED Status Panel

LED Status Panel—Pump Unit

The LED status panel plugs into a 10-way black connector on the left hand side of the Master Unit and Remote Unit controller PCB. This board provides indication of the link activity and states of Pumps.

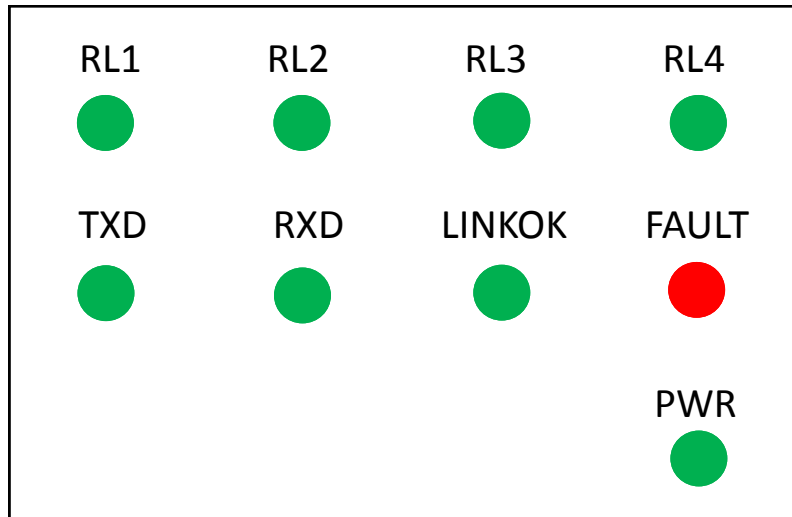

Figure 2. LED Status Panel

LED	Description	Function
RL1	Pump ON	ON = Pump 1 on, OFF = Pump 1 off
RL2	Floats OK	ON = Floats OK, OFF = Float Error
RL3	Battery OK	ON = Tank Battery > 11.6V, OFF = Battery Low
RL4	Not Used	N/A
TXD	Transmit Activity	Blinks when sending data to Pump Unit
RXD	Receive Activity	Blinks when receiving data from Remote Unit
LINKOK	Healthy Radio Link	ON when Radio link OK, OFF if Radio link fault
FAULT	Fault Detected	ON when any Radio Fault, OFF when link OK
PWR	Power OK	ON when power applied to unit

Table 2. Functions of Pump LED Status Panel

Tank Unit Wiring

The Tank unit must be powered by 12/24V DC (Current requirement < 100mA peak). Typically powered by 10 Watt Solar Power supply kit.

The HIGH float switch is connected between input “D3” and “GND”

The LOW float switch is connected between input “D2” and “GND”

Pump Unit Wiring

The Pump unit must be powered by 12/24V DC (Current requirement < 100mA peak). Note: If GSM option is fitted, the supply must be able to supply up to 2A.

Alarm and Pump control relays are pre-wired. NOTE: If the GSM option is fitted then a Power Up text message will be send each time the unit has power removed and re-applied.

Antenna

The Antenna kit is shipped with the whip removed from the base. Use a 2.5mm Alan Key (Not Supplied) to loosen the grub screw on the antenna base. Insert whip into base and then tighten using Alan Key.

The antenna should be mounted as high as possible and in good view of the antenna at the other end of the link. Ensure the whip part of the antenna is not located close to metal objects.

Optional Monitor/Over-ride Unit

The Everpump system can be supplied with an optional Monitoring unit. This unit will indicate all transmit and receive activity from Tank Unit and Pump Unit, display Healthy link indication and provide a Manual over-ride facility to switch the Pump ON or OFF as desired.

In order for the Monitoring Unit to operate, all signals from the Tank unit are sent directly to the Monitor Unit instead of the Pump Unit. All control information to the Pump Unit is controlled by the Monitor Unit. Note: *If the Monitor Unit is switched OFF or removed, the system will no longer operate.*

How it works

To use the standard Everpump system with a Monitor unit it is necessary to add a wire link between the “D4” terminal and “GND” terminal on the Pump Unit controller board.

The Monitor Unit is typically located in a house or some central location between the Tank Unit and Pump Unit. The Monitor Unit has 2 operating modes that are set by the Auto/Man switch on the front panel of the Monitor Unit.

AUTO: In Automatic mode, all signals from the Tank Unit are diverted immediately to the Pump Unit and the front panel ON/OFF switch has no effect.

MAN: Manual mode enables the pump to be switched ON or OFF as desired. When in Manual mode the Monitor unit ignores pump switching information from the Tank Unit and instead sets the state of the Pump based on the state of the ON/OFF switch. If the switch is ON, the pump will be on and visa-versa.

Whenever the float switches at the tank unit change state (or a 15 minute period exists with no change of state) then the Tank Unit will send a signal to the Monitor Unit. The Monitor unit will display the fact that the Radio link to the Tank Unit is OK and send an acknowledgment signal back to the Tank Unit. The Monitor Unit will also display the “transmit” (TXD) and “receive” (RXD) activity from and to the Tank Unit as messages are being received and sent respectively.

If the Mode switch of the Monitor Unit is set to manual mode (“MAN”) then no more action will follow with regard to the Tank Unit message.

If the Mode switch is set to automatic mode (“AUTO”) then the Monitor unit will send the message from the Tank Unit on to the Pump Unit. The Pump Unit will then set the pump ON or OFF and send an acknowledge message back to the Monitor Unit. The Monitor Unit will display the TXD and RXD activity to and from the Pump Unit and display the Radio Link OK for Pump Unit.

In this manner, the Monitor Unit indicates all activity between the Tank Unit and the Pump Unit displays the Healthy radio link status (or fault) and allows manual control of the pump.

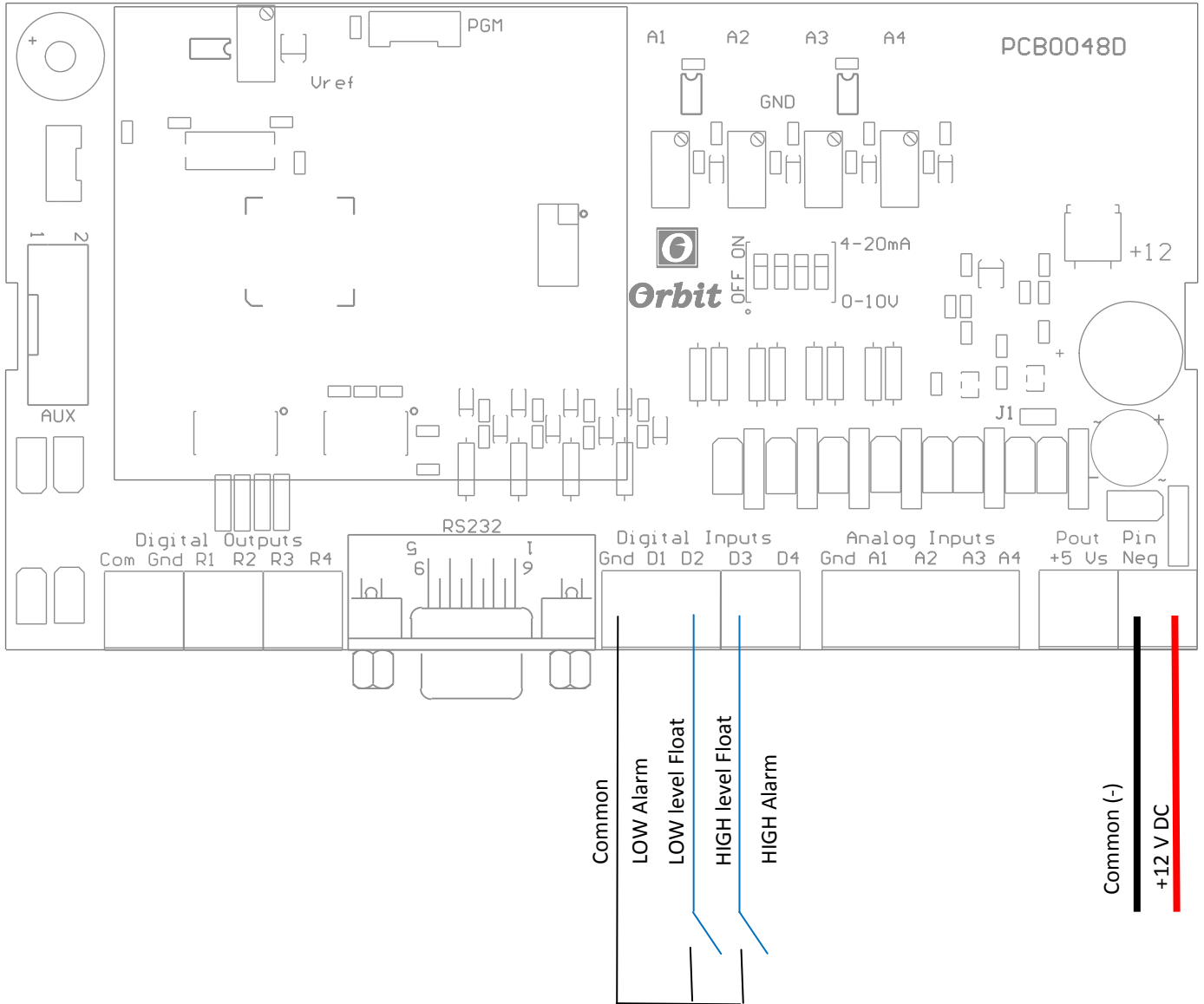

Figure 3. Wiring diagram for TANK Unit

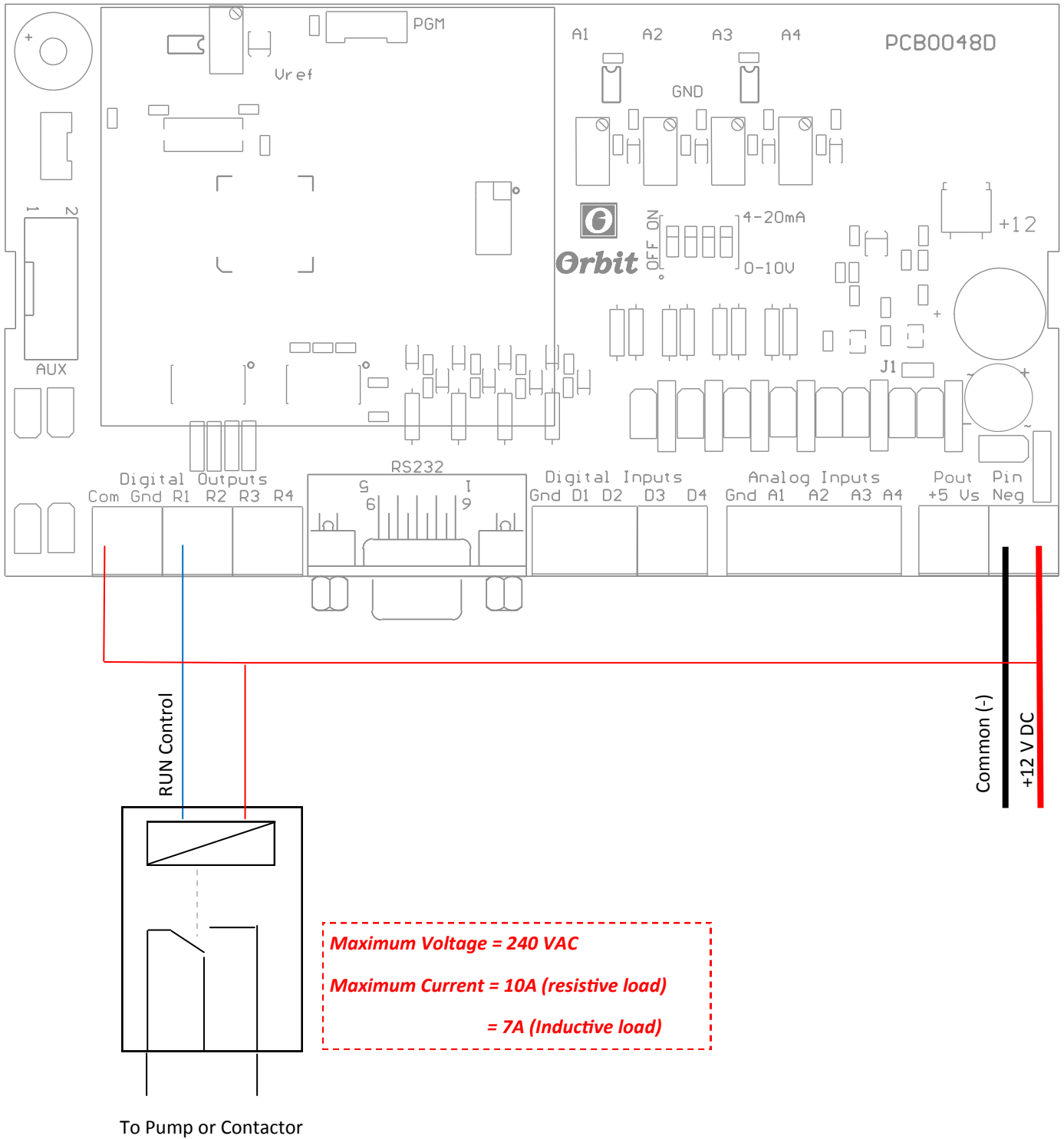

Figure 4. Wiring diagram for PUMP Unit

Digital Inputs

The Digital Inputs are pulled up to +5V DC via an internal pull-up resistor. The inputs can tolerate over voltage and reverse polarity voltage to +/- 30V DC. ***Voltages applied outside of this range may cause damage.***

The Digital inputs can be operated using any voltage free contact (such as a Relay contact, open drain or open collector output from another device or a switch), the input can also be connected to a voltage source (recommend 0V to 10V maximum). Note: The Common side of the input devices must connect to the GROUND terminal of the RTU device.

Digital Outputs

The RTU Digital outputs are Open Collector type and can tolerate a maximum applied voltage of 50VDC and a sink maximum current of 500mA.

Typical applications use the Digital outputs to control relay coils. The outputs are also suitable to connect directly to inputs of other devices (such as a PLC) that require Voltage-Free inputs or for driving indicators such as LEDs.

Relay Connections

The supplied relay provides two changeover relay contacts. The recommended method is to connect the Pump or contactor between Normally OPEN (N/O) and Common contacts (either A or B as shown below). The relay contacts are rated up to 240VAC and current handling capacity to 7 Amps for an inductive load (such as a motor) and 10 Amps for resistive loads.

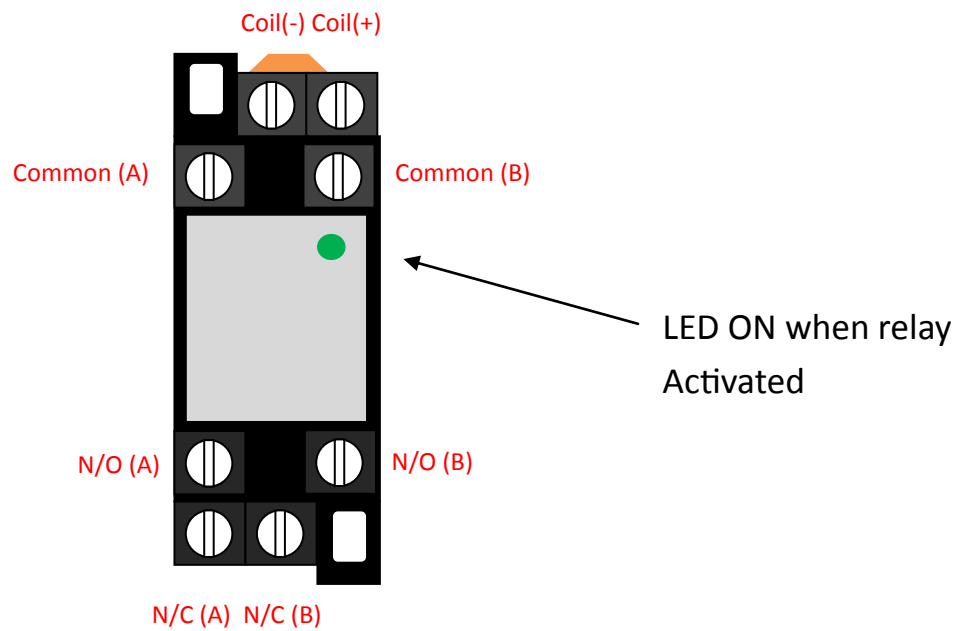

Figure 4. Relay Contact Details

Fitting PCB to DIN Rail

Tilt rear of unit down to enable base to clip onto back of DIN rail

Lower front and press onto DIN rail until locking mechanism clicks into place

Removing PCB from DIN Rail

Use small screwdriver for pull locking TAB (at front of unit) toward you.

Lift Unit up at front and then and away from DIN Rail

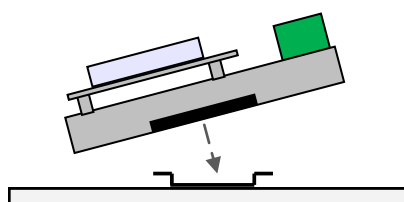

Figure 5. PCB attachment to DIN rail

Safety Precautions

The following safety precautions must be observed whenever the Orbit wireless device system is in operation or in service. Failure to comply with these precautions violates the safety standards of the design, manufacture and intended use of the product

- The system is not to be used:

In hospitals or places where medical equipment may be in use.

In an aircraft (whether on the ground or in the air)

Refuelling points

Explosive areas

- Restricted use of the Orbit wireless device

Near any chemical plant

Near any Fuel depot

The Orbit wireless device system receives and transmits radio frequency energy while switched on, therefore interference can occur if the Orbit wireless device is located near TVs, radios, PCs or any inadequately shielded equipment.

WEEE directive 2002/96/EC, disposal of old electronic equipment

This product shall not be treated as household waste. It must be placed at an appropriate collection point for the recycling of electrical and electronic equipment. By ensuring the correct disposal of this equipment, it will help the environment and human's health. The recycling will help to conserve the natural resources.

Important

Due to the nature of wireless systems, transmission and reception of data can never be guaranteed. Data may be corrupted (i.e. Have errors) or be totally lost at certain times due to the environment, other machinery or malfunction of electronic components. Although significant loss of data are rare when wireless devices such as the Orbit wireless device system are used in a normal manner, Orbit's wireless device system should not be used in situations where failure to transmit or receive data could result in damage of any kind to the user or any other party, including but not limited to personal injury, death or loss of property. Orbit Communications Pty Ltd accepts no responsibility for damages of any kind resulting from errors in data transmitted or received using Orbit's Orbit wireless device systems, or for the failure of the Orbit wireless device system to transmit or receive such data.

Do not operate the Orbit wireless device system in areas where blasting is in progress, where explosive atmospheres may be present, near medical equipment, near life support equipment, or any equipment which may be susceptible to any form of radio interference, in such areas, Orbit's wireless device system must be powered OFF.

Do not operate Orbit wireless device system in any aircraft, whether the aircraft is on the ground or in flight. In an aircraft the Orbit wireless device system must be powered OFF.

The information in Orbit Communications Pty Ltd documents are subject to change without notice and do not represent a commitment on the part of Orbit Communications Pty Ltd. Orbit Communications Pty Ltd and its affiliates specifically disclaim liability for any and all direct, indirect, special, general, incidental, consequential, punitive or exemplary damages including, but not limited to, loss of profits or revenue or anticipated profits or revenue arising out of the use or inability to use any Orbit Communications Pty Ltd product, even if Orbit Communications Pty Ltd and/or its affiliates have been advised of the possibility of such damages or they are foreseeable or for claims by any third party.

Notwithstanding the foregoing, in no event shall Orbit Communications Pty Ltd and/or its affiliates aggregate liability arising under or in connection with the Orbit Communications Pty Ltd product, regardless of the number of events, occurrences or claims giving rise to liability, be in excess of the price paid by the purchaser for the Orbit Communications Pty Ltd product.

Warranty

All products manufactured by Orbit Communications Pty Ltd are warranted to be free from defects in materials and workmanship under normal use and service for 36 months from the date of shipment unless otherwise specified. Orbit Communications' obligation under this warranty is limited to repairing or replacing (at Orbit's discretion) defective products. The customer shall assume all costs of removing, reinstalling and shipping defective products to Orbit Communications. Orbit Communications will return such products by surface carrier prepaid. This warranty shall not apply to any Orbit product that has been subject to modification, misuse, neglect, accidents of nature or shipping damage. This warranty is in lieu of all other warranties, expressed or implied, including warranties of merchantability or fitness for a particular purpose. Orbit Communications is not liable for special, indirect, accidental, or consequential damages.

Products may not be returned to Orbit Communications without prior authorization. To obtain a Returned Product Authorization (RPA), contact Orbit Communications by phone, fax or email. An RPA number will be issued after our staff determines the nature of the problem. Please write the RPA number on the outside of the shipping container. Any non-warranty products returned for repair should be accompanied by a purchase order to cover the cost of the repairs.