

# INSTALLATION INFORMATION FOR RTU Wireless Input/Output

## INTRODUCTION

The RTU (Radio Telemetry Unit) wireless Input/Output system offers reliable remote control and monitoring for a variety of applications.

The system is available as Digital Input/Output only or Digital and Analog Input/Output.

The part numbering for the RTU system specifies the number of digital input and output functions and enclosure format for each particular model.

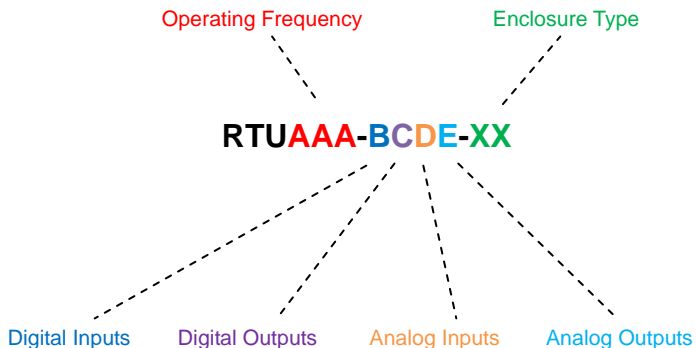

### Available frequencies

- 151 MHz
- 433 MHz
- 915 MHz
- 2400 MHz

### Available Inputs and outputs

- 4 Digital Inputs
- 4 Digital Outputs
- 4 Analog Inputs
- 2 Analog Outputs

### Available Enclosure Types

- PCB DIN rail mountable PCB only (157x86x35mm)
- ID Indoor IP65 ABS enclosed (220x165x55mm)
- OD Outdoor IP65 Polycarbonate enclosed (280x190x140mm)
- OD-L Large Outdoor enclosure (320x320x140mm)

## INPUT/OUTPUT CONFIGURATION

The following description of Inputs and Outputs is common to all versions of RTU.

### Digital Inputs

The Digital Inputs are pulled up to +5V DC via an internal pull-up resistor. The inputs can tolerate over voltage and reverse polarity voltage to +/- 30V DC. Above this level damage may occur.

The Digital inputs can be operated using any voltage free contact (such as a Relay contact, open drain or open collector output from another device or a switch), the input can also be connected to a voltage source (recommend 0V to 10V maximum).

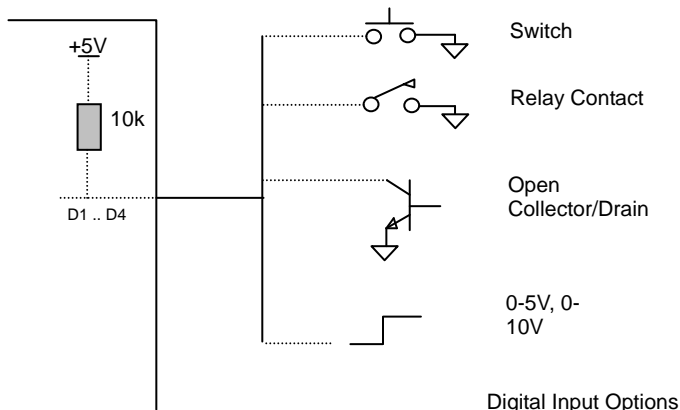

Digital Input Model  
(Protection not shown for simplicity)

### Digital Outputs

The RTU Digital outputs are Open Collector type and can tolerate a maximum applied voltage of 50VDC and a maximum current sink of 500mA.

Typical applications use the Digital outputs to control relay coils. The outputs are also suitable to connect directly to inputs of other devices that require Voltage-Free inputs or driving indicators such as LEDs.

The digital Outputs each have a protection Diode built-in that are connected to a "COMMON" output on the PCB (labelled "Com"). If Com is connected to the positive common side of the relay coils, this will provide transient switching protection for the outputs.

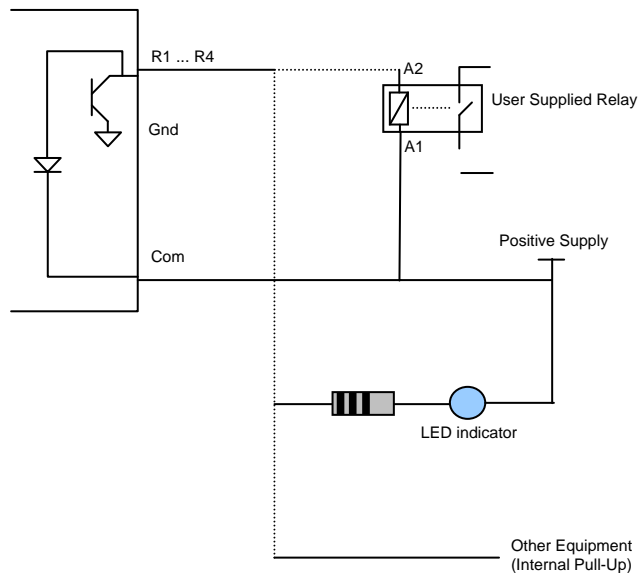

### Analog Inputs

RTU analog inputs can be configured to accept 4-20mA current loop sensors or voltage input (such as 0-2.5V, 0-5V or 0-10V).

A DIP switch enables selection between current or voltage input for each of the Analog inputs.

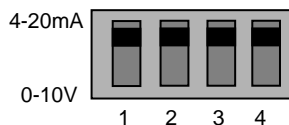

When switched to the top position, the corresponding input is configured as an Analog input. Switching to the lower position changes the configuration to a voltage input.

- Input resistance (4-20mA mode) = 250 Ohms.
- Input resistance (0-10V mod) = 20K Ohms.
- Maximum DC voltage = 28V.

For low power applications the Vsw output provides switched DC voltage to power sensors. The voltage is applied only when a reading is to be taken and then the voltage is removed to conserve power. The operation of this output can be set to Always ON or Switched via the RS232 port and a computer running Orbit Configuration software. The time the switched voltage is applied before a reading is taken is also programmable.

### Analog Outputs

RTU Analog outputs provide 4-20mA current source. The compliance voltage is 12V DC. The default output format is 4-20mA. A value of 0mA represents a fault. The range can be set to 0-20mA using the serial port and Orbit Software.

To produce a Voltage output, a resistor can be placed across the output. The range of the output voltage can be calculated as follows...

$$R = \text{required maximum Volts} / 20\text{mA}$$

Example: for 0-10V output  $R = 10/20\text{mA} = 500 \text{ Ohms}$ .

# INSTALLATION INFORMATION FOR RTU Wireless Input/Output

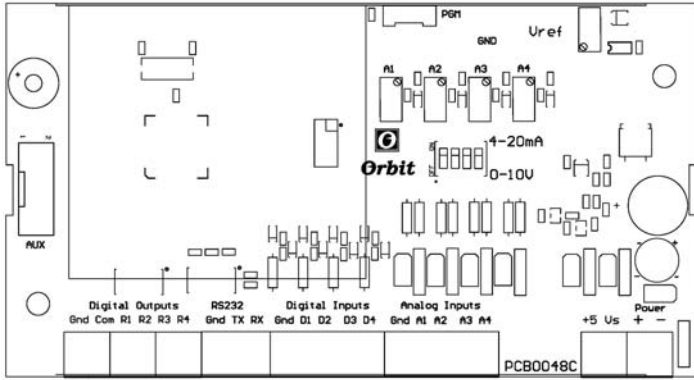

Overlay view of RTUXXX-4440 Unit

## INSTALLATION – PCB Version

The RTUXXX-PCB unit is supplied with an Antenna cable (1m length) soldered directly to the PCB that is terminated with a TNC bulkhead style connector.

The user is responsible for mounting the RTU unit into a suitable enclosure and providing 12/24V DC or AC power.

Connection to the power supply and various input and output pins are via 5mm pitch Screw Terminal Blocks.

The RTUXXX-PCB is supplied attached to a plastic DIN rail compatible Base plate. (Suitable for standard 35mm Top Hat DIN Rail).

The user must mount the RTUXXX-PCB unit into an appropriate enclosure that will protect the unit from the elements in the given site environment. (i.e. At least IP65 rated for environments that are subject to water or moisture, UV stabilized and IP65 rated for outdoor applications etc).

The RTUXXX-PCB unit requires a certain amount of free space inside the enclosure to enable easy connection to the screw terminal blocks and routing of the antenna cable.

### Minimum recommended space around unit

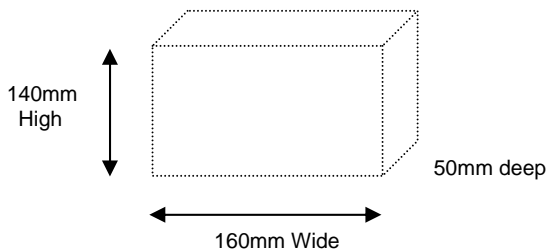

This is the minimum internal space required around the module inside the enclosure to enable correct installation.

The recommended minimum length of DIN rail is 160mm.

The antenna TNC bulkhead connector requires a 12.8mm mounting hole (13mm max) to be drilled into the enclosure to properly secure the connector to the outside of the case. The Antenna bulkhead connector provides IP65 rated water and dustproof protection. (Note: Unused antenna cable can be coiled inside enclosure)

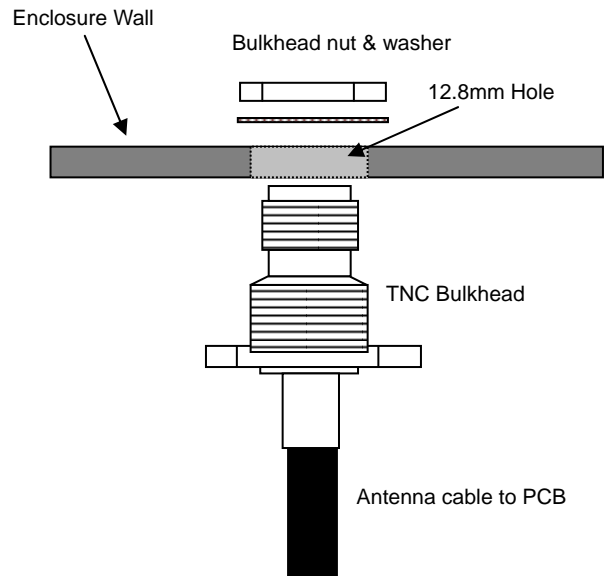

The enclosure should be mounted in such a manner as to enable enough room for the antenna cable to be attached to the TNC bulkhead. It is recommended that at least 80mm free space is available out from the antenna connector to leave room for the antenna kit Plug and not too tight radius to bend the antenna cable.

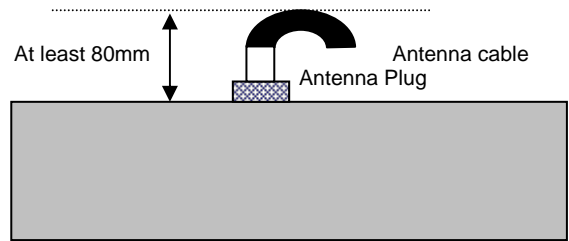

If the RTU151-4400-PCB unit was supplied with a small "Stubby" antenna, at least 150mm free space should be left above the unit for the antenna, the enclosure, the unit should be mounted so that the antenna is as far away from metal objects as possible and that there is clear line of sight path to the antenna if possible.

For external Antenna kits, the kit is supplied with 5m of cable and a metal "L" mounting bracket that enables the antenna to be mounted in a position that is high as possible from ground and away from metal objects. (Antenna Extension cables are available from Orbit if 5m is not long enough in the particular installation.)

The External Antenna kit has a high gain whip antenna that is almost 1m in length.

**WARNING: Care must be taken not to touch overhead power wires or other sources of danger when working above ground – Including care taking care to use a safety harness.**

**Lightning protection devices are available from Orbit Communications if the system is to be installed in a high lightning activity area.**

# INSTALLATION INFORMATION FOR RTU Wireless Input/Output

## DIN RAIL MOUNTING

Dimensions of DIN mounting base including Quick-Release TAB.

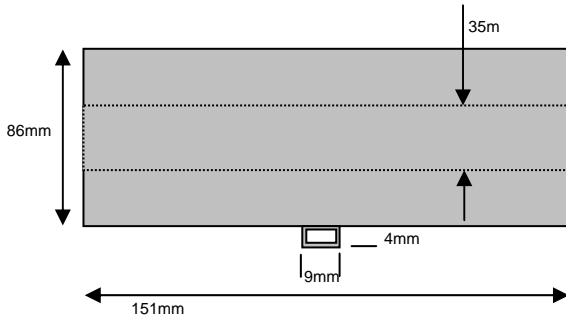

### Fitting Unit to DIN Rail

1. Tilt rear of unit down to enable base to clip onto back of DIN rail
2. Lower front and press onto DIN rail until locking mechanism clicks into place

### Removing Unit from DIN Rail

1. Use small screwdriver for pull locking TAB (at front of unit) toward you.
2. Lift Unit up at front and then away from DIN Rail

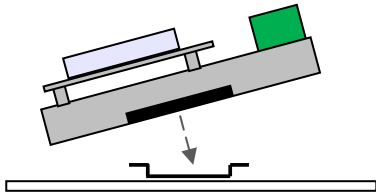

### Optional Relay kits provided with "OD" versions

The "OD" version of RTU is available with up to 4 Relays pre-fitted and wired. The relays plug into a DIN rail mountable base and are fitted to a 35mm "Top Hat" style DIN rail inside the OD enclosure. Available coil voltages are 12V DC, 24V DC and 240 VAC.

The contacts provide up to 10 Amps (7 Amps inductive) switching current up to 240 VAC. Two (2) sets of Normally OPEN, Normally CLOSED and COMMON contacts are provided and each relay has a LED that indicates when it is Active.

The RTUXXX unit has a "Common" terminal that is connected to the positive (+) or power side of each relay coil. The common terminal provides a protection diode for each Digital output to the common supply to prevent damage caused by switching transient voltages.

The Switched side of each relay is then connected to the respective Digital output (R1 to R4). The RTU activates a relay by pulling the Digital Output (open collector) pin to ground potential and therefore causing current to flow through the respective coil and closing the normally open to Common contacts.

